



life.augmented

STMicroelectronics SubGHz SoC's Spirit, STM32WL

Tim Nakonsut

Product Marketing, Microcontrollers

The STM32WL logo, featuring the ST logo above the text 'STM32WL' in a bold, sans-serif font, all contained within a yellow square.

STM32WL

STMicroelectronics Sub-1 GHz offer

Sub-GHz
Transceiver

Sub-GHz SoC
Application processor



STM32Cube
Expansion package

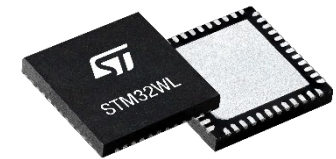

STM32Cube
MCU package



SubGHz
proprietary





STM32 MCU “Wireless” series

More than **60,000** customers

Over **6 billion** STM32 shipped since 2007

 MPU

STM32MP1
 4158 CoreMark
 650 MHz Cortex -A7
 209 MHz Cortex -M4

 High Perf MCUs

STM32F2 Up to 398 CoreMark 120 MHz Cortex-M3	STM32F4 Up to 608 CoreMark 180 MHz Cortex-M4	STM32F7 1082 CoreMark 216 MHz Cortex-M7	STM32H7 Up to 3224 CoreMark Up to 550 MHz Cortex -M7 240 MHz Cortex -M4	STM32H5 1023 CoreMark 250 MHz Cortex-M33
---	---	--	---	---

 Mainstream MCUs

STM32F0 106 CoreMark 48 MHz Cortex-M0	STM32G0 142 CoreMark 64 MHz Cortex-M0+	STM32F1 177 CoreMark 72 MHz Cortex-M3	STM32F3 ● 245 CoreMark 72 MHz Cortex-M4	STM32G4 ● 550 CoreMark 170 MHz Cortex-M4
Optimized for mixed-signal Applications				

 Ultra-low Power MCUs

STM32L0 75 CoreMark 32 MHz Cortex-M0+	STM32L1 93 CoreMark 32 MHz Cortex-M3	STM32L4 273 CoreMark 80 MHz Cortex-M4	STM32L4+ 409 CoreMark 120 MHz Cortex-M4	STM32L5 443 CoreMark 110 MHz Cortex-M33	STM32U5 651 CoreMark 160 MHz Cortex-M33
--	---	--	--	--	--

 Wireless MCUs

STM32WL ● 162 CoreMark 48 MHz Cortex-M4 48 MHz Cortex-M0+	STM32WB ● 216 CoreMark 64 MHz Cortex-M4 32 MHz Cortex-M0+	STM32WBA 407 CoreMark 100MHz Cortex-M33
---	---	--



● Optimized for mixed-signal applications

● Dual-core architecture: Cortex-M4 and M0+





System-on-chip made for versatility

A long-range wireless microcontroller: one die, many IoT possibilities

World first!

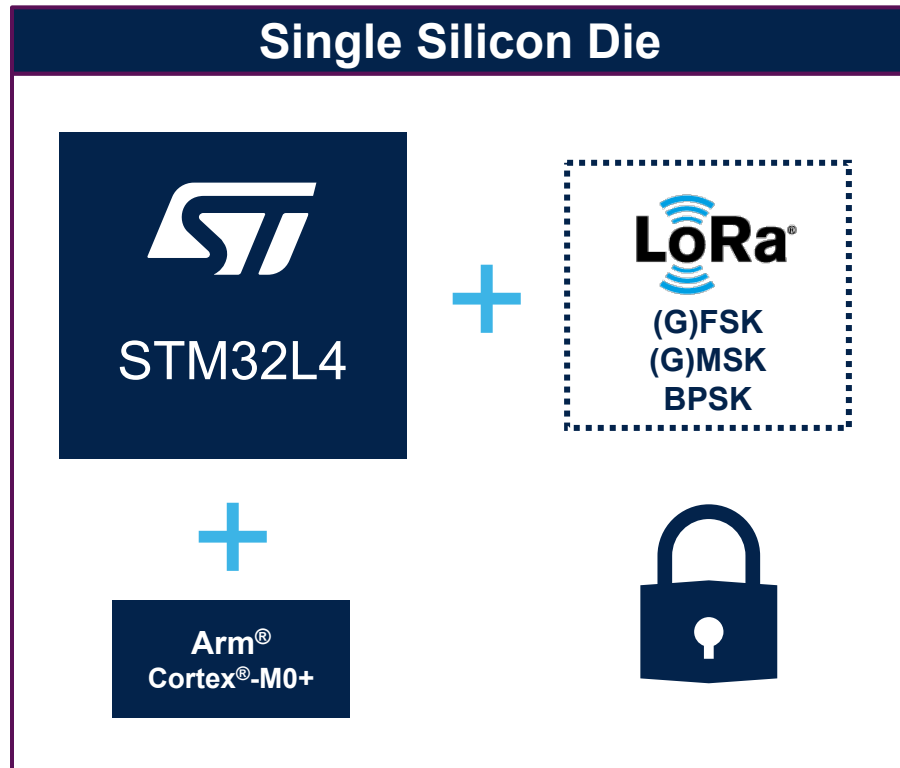

=





STM32 SubGHz Portfolio

SubGhz SoC Dual Core

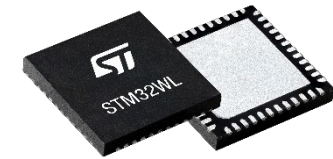

STM32WL5x

SubGhz SoC Single Core

STM32WL3x*
(ex- SPIRIT3)
Coming soon

STM32WLEx

SubGhz Transceiver

1st Generation SPIRIT1



General Purpose Sub-1GHz radio

2nd Generation S2LP



Ultra Low Power Sub-1GHz radio

2 (G)FSK
(G)MSK
-
OOK
ASK
-

2/4 (G)FSK
(G)MSK
BPSK (Sigfox)
OOK
ASK
*DSSS on WL3

2 (G)FSK
(G)MSK
BPSK (Sigfox)
-
-
LoRa (WLx5 P/N)

STM32WL5x Line - a rich feature set

Dual-core and enhanced security

Control	Arm® Cortex®-M4 DSP 48 MHz	Memory
Power supply 1.8 to 3.6 V w/ DCDC+ LDO POR/PDR/PVD/BOR	Nested vector interrupt controller (NVIC)	Up to 256-Kbyte Flash
Crystal oscillators 32 MHz (Radio + HSE) 32.768 KHz (LSE)	Memory protected unit (MPU)	Up to 64-Kbyte SRAM
Internal RC oscillators 32,768 KHz + 16 MHz + 48 MHz ± 1% acc. over V and T(°C)	JTAG/SW debug	CM4 or CM0 Boot Lock
RTC/AWU/CSS	ART Accelerator™	Boot loader
PLL	AHB Bus matrix	Hide protect
SysTick timer	2x DMA 7 channels	
2 watchdogs (WWDG/IWDG)	Radio	Timers
43 GPIOs	LoRa®, (G)FSK, (G)MSK, BPSK	1 x 32-bit timer
Cyclic redundancy check	+15dBm & +22dBm Power Outputs -148 dBm sensitivity (LoRa)	3x 16-bit timers 3x ULP 16-bit timers
Voltage scaling (2 modes)	150 MHz to 960 MHz	Analog
		1x 12-bit ADC SAR 2.5 Msps
		12-bit DAC
		2x ULP comparators
		Temperature sensor
Security	Arm® Cortex®-M0+ 48 MHz	Connectivity
AES 256-bit + TRNG + PCROP	Nested vector interrupt controller (NVIC)	2x SPI, 3x I2C
Tamper detection	Memory protected unit (MPU)	2x USART LIN, smartcard, IrDA, Modem control
Secure Areas	SW debug	1x ULP UART
Secure FW Install		
Debug control		
Boot Selection		
Secure Sub-GHz, MAC Layer, SFI		
Key Management Services		

KEY FEATURES

- Arm® Cortex®-M4 & DSP up to 48 MHz
- Up to 256 KB Flash and 64 KB SRAM
- Arm® Cortex®-M0+ up to 48 MHz
- **Sub-GHz Radio**
 - Multi-modulation: LoRa, (G)FSK, (G)MSK, BPSK
 - 2 embedded power amplifiers:
 - 1 output up to +15 dBm
 - 1 output up to +22 dBm
 - LoRa RX sensitivity: -148 dBm (SF12, BW=10.4kHz)
 - RX: 4.82mA and TX: 15mA (at 10dBm) / 87mA (at 20dBm) [3.3V]
- **Ultra-Low Power consumption**
 - < 71µA/MHz Active mode (3V - RF OFF)
 - 1 µA Stop2 mode with RAM retention
 - 390 nA Standby mode with RTC
 - 31 nA Shutdown mode
- **Peripherals**
 - 3xI²C, 2xUSART, 1xLP-UART, 2xSPI
 - 7x timers + 2x ULP Comparators
- **Advanced security features**
 - 1.8 to 3.6V voltage range (DC/DC, LDO)
 - -40 to up to +105°C temperature range



-> Packages: QFN48, BGA73

Flexible power scheme FlexPowerControl

Typ with LDO @ $V_{DD} = 3\text{ V}$ @ $25\text{ }^\circ\text{C}$



* Typical values with SMPS, RF OFF
 ** with RTC on LSE Bypass
 *** All OFF

Benchmark scores

- High Efficiency
 → CoreMark score = 162
- Ultra Low-Power Platform
 → ULPBbench score \approx 204

4 modulations - many protocols

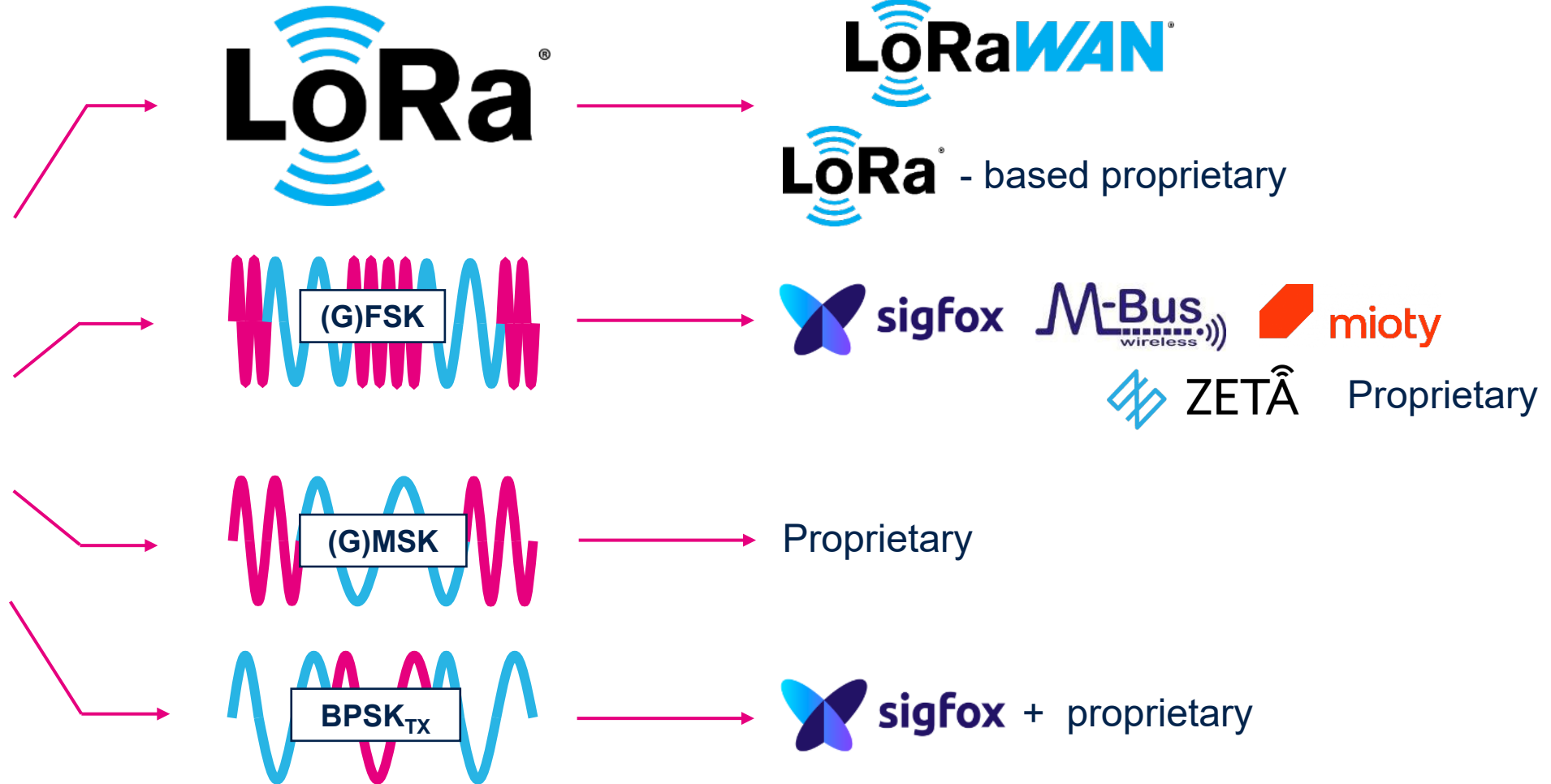

STM32WL - safety and security

Secure your application with embedded safety & security



Safety

- Back-up clock circuitry
- Supply monitoring
- Dual watchdog
- Flash memory with ECC (address status register)
- SRAM Parity check
- Cyclic Redundancy Check
- Brown-out reset in all modes
- Clock Security System
- Backup byte registers



Security

- Tamper detection
- Read & Write protection
- Memory Protection Unit (MPU)
- Software IP Protection
- True Random Number Generator
- AES and Public Key Accelerator
- Unique IDs (64- and 96-bit)
- Boot-Lock in user Flash
- **Secure hardware isolation between CM4 / CM0**
- **Boot selection**
- **Secure Boot code protection**
- **Debug control**
- **Secure Firmware Install**
- **Secure Boot Secure Firmware Update***
- **Key Management Services***
- **Crypto Library***

Available on
STM32WL5x dual-core versions

Bring more security to your LoRaWAN apps

Your implementation, your choice

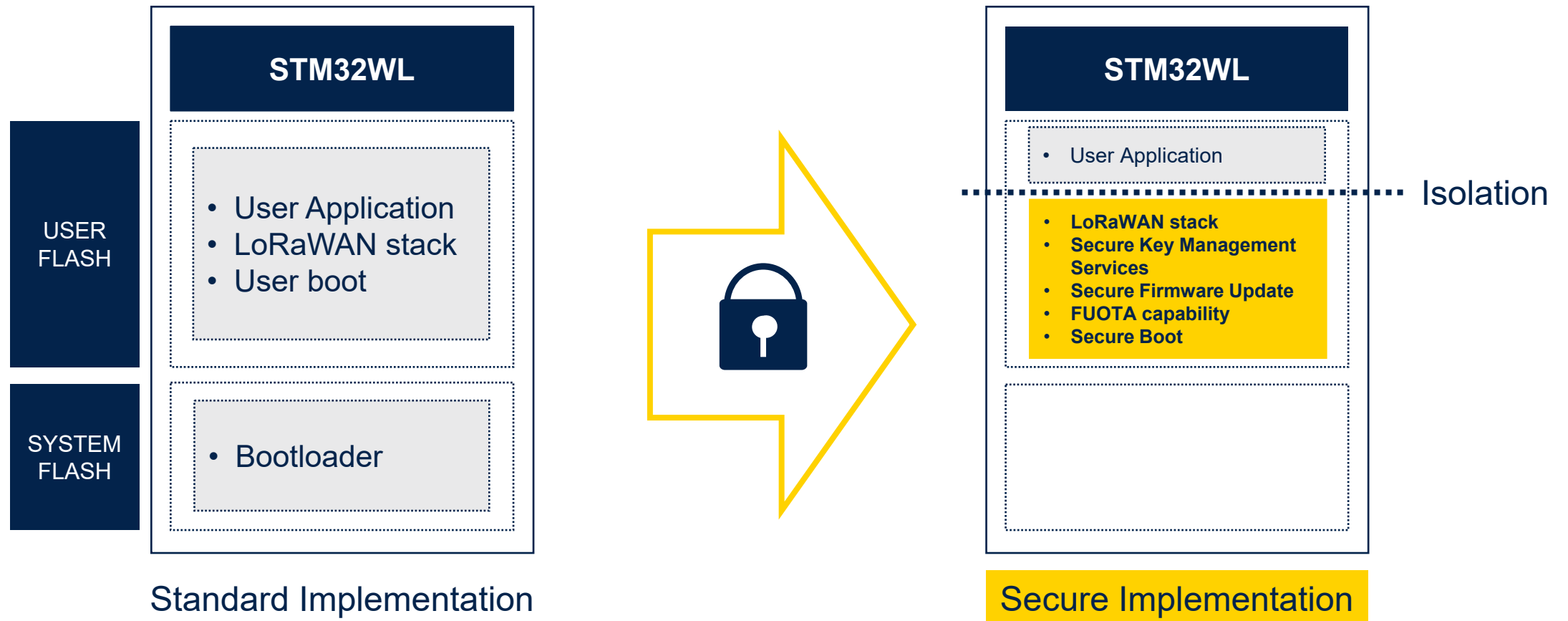

Flexible power implementation

Tailor STM32WL to the requirements of IoT applications

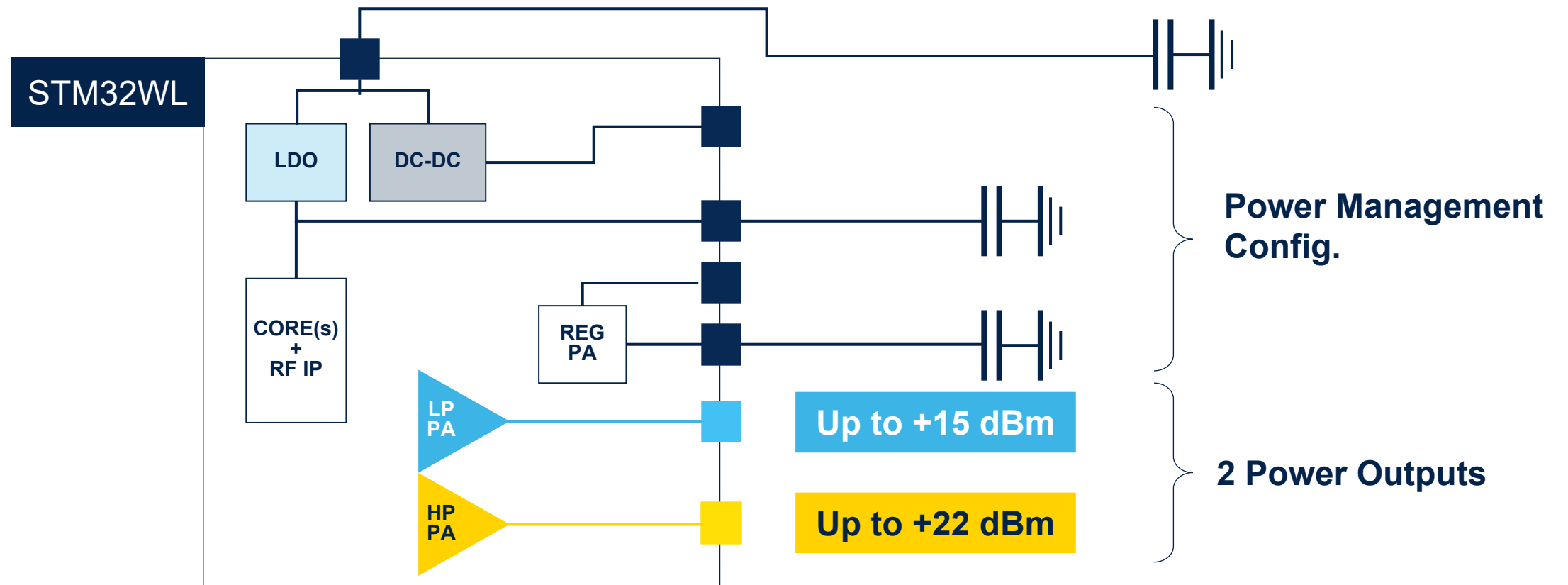



STM32WL IPD Integrated Passive Device

STM32WL RF Front end in a 1.2mm²

BEFORE

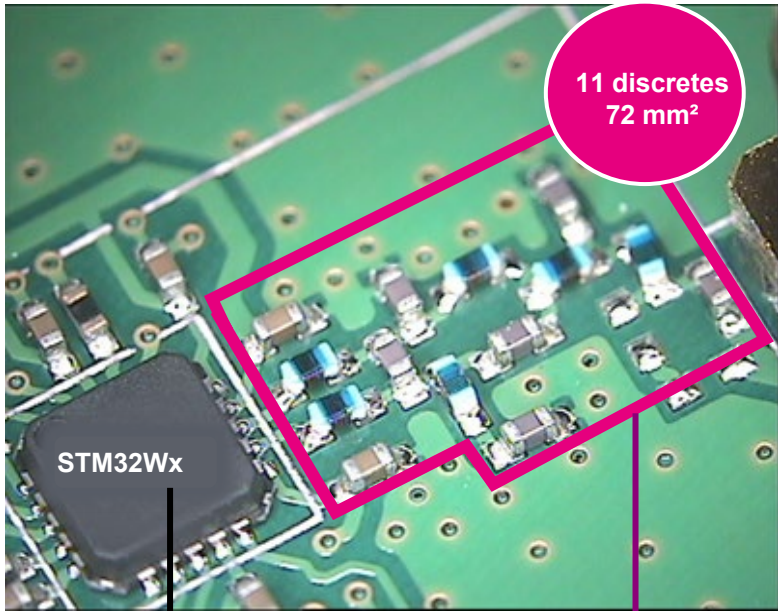

Wireless MCU Discrete balun & matching network

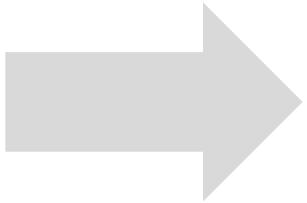

AFTER

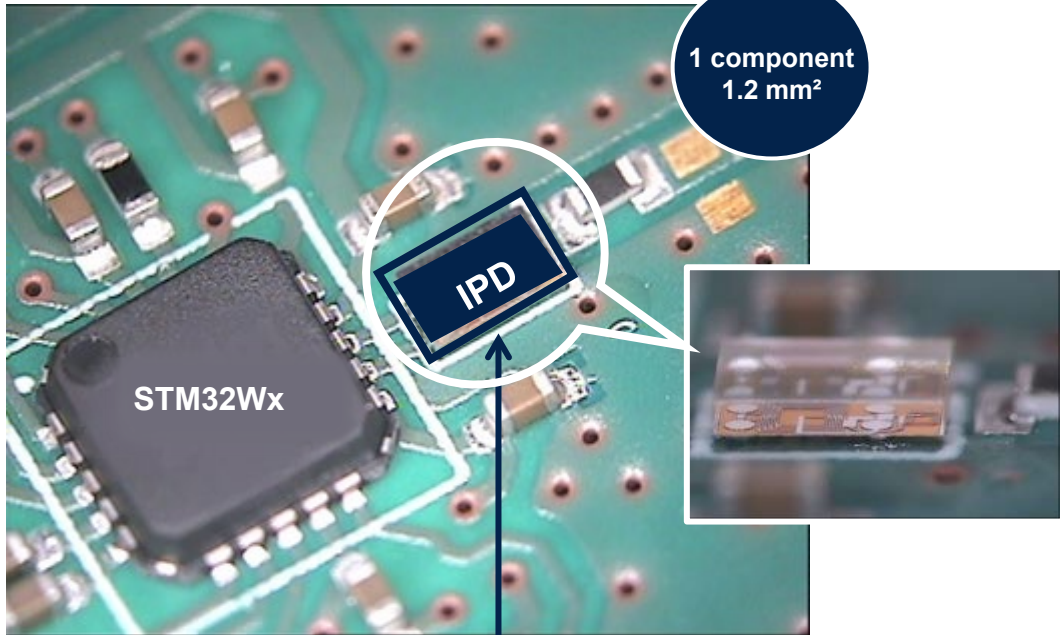

RF IPD balun & matching network



STM32W Sub-GHz – large portfolio

Flash / RAM
Size (bytes)

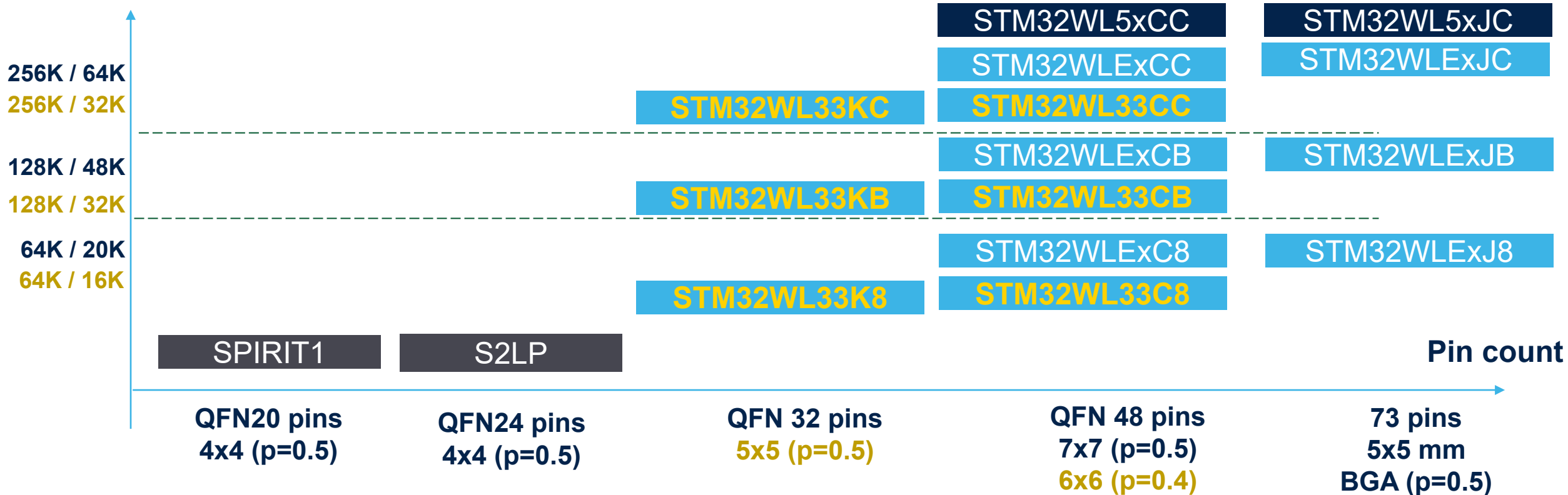

The STM32WL Nucleo-64 at a glance

Main Features

NUCLEO-WL55JC1

868/915/923 MHz

NUCLEO-WL55JC2

433/470 MHz

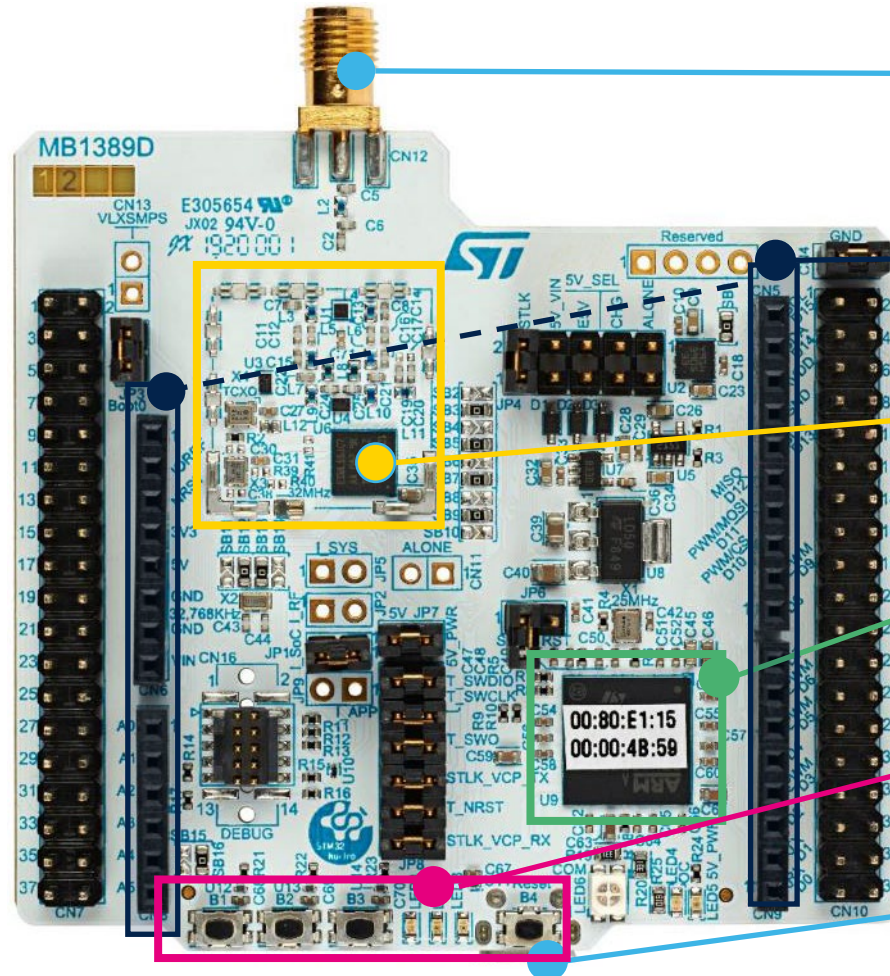

SMA Antenna connector

Arduino™ extension connectors :
easy access to add-ons

STM32WL
(under a metallic shield)

Integrated ST-LINK/V3:
mass storage device flash programming

4 push buttons, 3 color LEDs,
Jumper settings

Flexible board power supply :
through USB or external source



S2-LP transceiver overview

Performance

Sub 1GHz

- 413-479MHz / 826-958MHz
- 452-527 MHz / 904-1055 MHz
- -40°C to +105°C
- QFN24 4x4x1

Radio performance

- 100bps to 500kbps
- -130dBm @ 0.3kbps
- +16dBm output power

Ultra low-power consumption

- Sleep / Shutdown: 700nA / 2.5nA
- Rx peak: 7mA
- Tx peak: 10mA @+10dBm



life.augmented

Protocols



Markets



Remote metering



Smart living



Alarm & surveillance



Smart home



Smart utilities



Healthcare & assistance



Smart parking



Smart agriculture



S2-LPTX overview

S2-LP based radio transmitter

Sub
1GHz

S2-LPTX

- 413-479MHz / 826-958MHz
- **Pin to Pin compatible** with S2-LP
 - **No need for a new Sigfox certification!**
- QFN24 4x4x1



Applications

- Asset Tracking
- Alarm System
- Home and Building Automation
- Remote key entry
- Wireless Sensor Networks



Radio performance

- 100bps to 500kbps
- **+16 dBm output power**



Ultra low-power consumption

- Sleep / Shutdown: 700 nA / 2.5 nA
- Tx peak current: **10 mA @ +10 dBm**

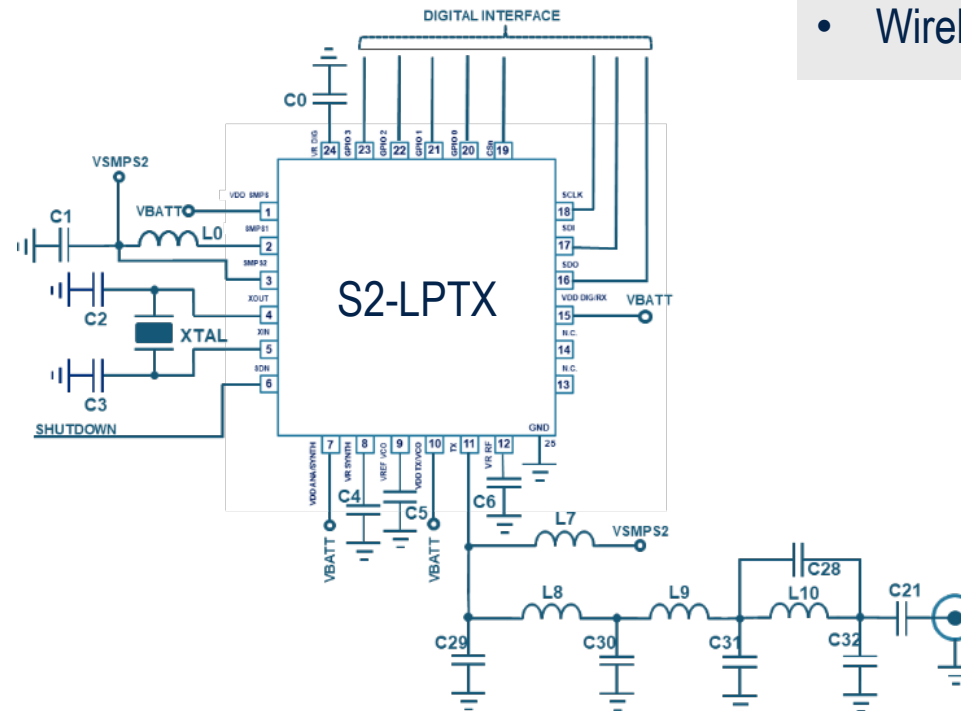

STM32WL – ecosystem overview

Fully integrated into the rich and market-proven STM32 ecosystem

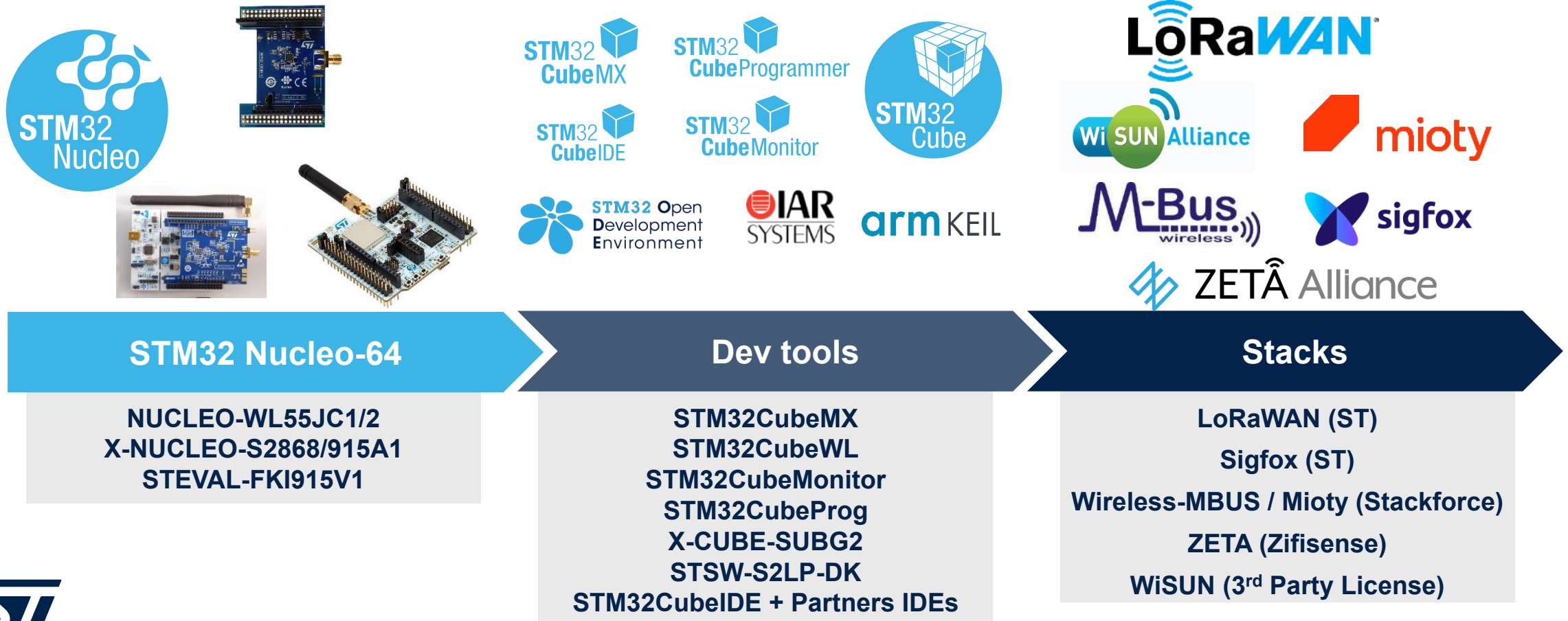

Releasing your creativity



[/STM32](#)



[@ST_World](#)



[community.st.com](#)



[https://www.st.com/en/wireless-connectivity](#)



[wiki.st.com/stm32mcu](#)



[github.com/stm32-hotspot](#)



[www.st.com/stm32-mcu-developer-zone](#)



Our technology starts with You



Find out more at www.st.com

© STMicroelectronics - All rights reserved.

ST logo is a trademark or a registered trademark of STMicroelectronics International NV or its affiliates in the EU and/or other countries.

For additional information about ST trademarks, please refer to www.st.com/trademarks.

All other product or service names are the property of their respective owners.



life.augmented